

Powerful and efficient with
3-phase AC drive motor

Extremely manoeuvrable
due to compact design

Maintenance-free gel battery
and integrated charger

Four mast heights available
(2.300 - 3.300 mm)



EJC M10 ZT/M13 ZT

Electric stacker trucks (1,000/1,300 kg)

The EJC M10 ZT/M13 ZT trucks were specially developed for the internal transfer of lightweight goods. The 0.6 kW drive motor supports the transport of pallets and goods weighing up to 1,300 kg over short distances.

The duplex mast, which is available in four different heights from 2,300 to 3,300 mm, makes the EJC M10 ZT/M13 ZT trucks the ideal helper for occasional picking as well as stacking of pallets. This is supported by the low frame height of the EJC M10 ZT/M13 ZT, which ensures that small operators also benefit from optimum visibility of the fork tips.

Thanks to the maintenance-free, powerful 3-phase AC motor,

energy consumption is reduced, thus providing the best conditions for rapid and cost-efficient goods throughput.

The EJC M10 ZT's compact design and its short front-end length (l2) of just 535 mm also guarantee maximum maneuverability. A gel battery used in conjunction with a built-in charger allows for flexible operation, without having to refill the battery with water.

The EJC M13 ZT draws on the supplied 160 Ah battery for the necessary energy, whilst the on-board charger ensures easy re-charging of the battery at any standard power outlet.

EJC M10 ZT/M13 ZT

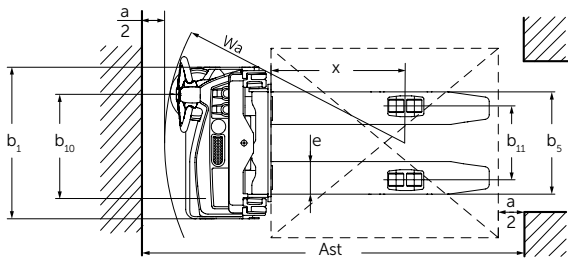
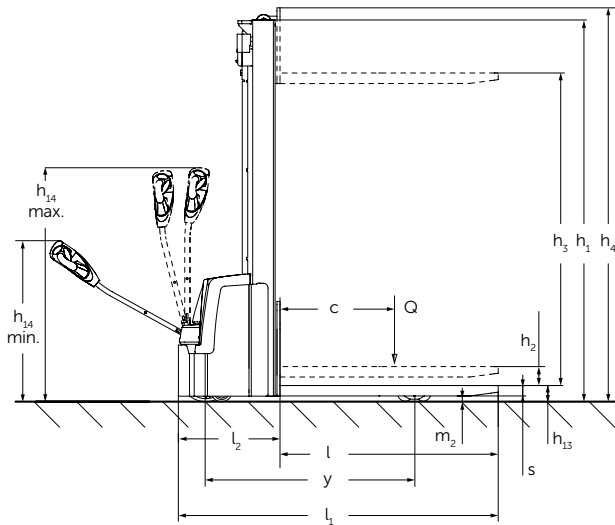

Standard mast types EJC M10 / EJC M13					Net weight incl. battery kg	
Duplex ZT	Lift h_3 mm	Closed mast height h_1 mm	Free lift h_2 mm	Extended mast height h_4 mm	EJC M10	EJC M13
	2300	1615	100	2730	589	659
	2500	1715	100	2930	598	704
	2900	1915	100	3330	616	722
	3300	2115	100	3730	634	740

Technical data in line with VDI 2198

		Jungheinrich					
		EJC M10 ZT	EJC M10 ZT	EJC M13 ZT	EJC M13 ZT		
Identification	1.1	Manufacturer (abbreviation)					
	1.2	Model					
	1.3	Drive	Electric				
	1.4	Manual, pedestrian, stand-on, seated, order picker operation	pedestrian				
	1.5	Load capacity/rated load	Q t	1	1	1.3	1.3
	1.6	Load centre distance	c mm	600			
	1.8	Load distance	x mm	710			
	1.9	Wheelbase	y mm	1,098	1,098	1,296	1,296
	Weights	2.1.1	Net weight incl. battery (see row 6.5)	kg	589	634	659
2.2		Axle load with load front/rear	kg	536 / 1,098	536 / 1,098	590 / 1,450	590 / 1,450
2.3		Axle load without load front/rear	kg	462 / 172	462 / 172	495 / 245	495 / 245
Wheels / frame	3.1	Tyres	TPU/PU				
	3.2	Tyre size, front	mm	Ø230x65			
	3.3	Tyre size, rear	mm	Ø80x70			
	3.4	Additional wheels (dimensions)	mm	Ø100x50			
	3.5	Wheels, number front/rear (x = driven wheels)		1x+1/4			
	3.6	Tread width, front	b ₁₀ mm	550			
	3.7	Tread width, rear	b ₁₁ mm	390			
Basic dimensions	4.2	Mast height (lowered)	h ₁ mm	1,615	2,115	1,615	2,115
	4.3	Free lift	h ₂ mm	100			
	4.4	Lift	h ₃ mm	2,300	3,300	2,300	3,300
	4.5	Extended mast height	h ₄ mm	2,730	3,730	2,730	3,730
	4.9	Height of tiller in drive position min. / max.	h ₁₄ mm	740 / 1,190			
	4.15	Height, lowered	h ₁₃ mm	85			
	4.19	Overall length	l ₁ mm	1,685	1,685	1,880	1,880
	4.20	Length to face of forks	l ₂ mm	535	535	728	728
	4.21	Overall width	b ₁ /b ₂ mm	800			
	4.22	Fork dimensions	s/e/l mm	55 / 172 / 1,150			
	4.25	Width across forks	b ₅ mm	540			
	4.32	Ground clearance, centre of wheelbase	m ₂ mm	30			
	4.33	Aisle width for pallets 1000 × 1200 sideways	Ast mm	2,136	2,136	2,330	2,330
4.34	Aisle width for pallets 800 × 1200 lengthways	Ast mm	2,103	2,103	2,297	2,297	
4.35	Turning radius	W _s mm	1,270	1,270	1,464	1,464	
Performance data	5.1	Travel speed, laden/unladen	km/h	4.5 / 5			
	5.2	Lift speed, laden/unladen	m/s	0.12 / 0.22			
	5.3	Lowering speed, laden/unladen	m/s	0.15 / 0.12			
	5.8	Max. gradeability, laden/unladen	%	4 / 10			
	5.10	Service brake		electric			
Electrics	6.1	Drive motor, output S2 60 min.	kW	0.6			
	6.2	Lift motor kW power at S3 7.5 %	kW	2.2			
	6.3	Battery as per DIN 43531 /35/36 A, B, C, no		no			
	6.4	Battery voltage/ nominal capacity	V/Ah	24 / 105 ¹⁾	24 / 105 ¹⁾	24 / 160	24 / 160
	6.5	Battery weight	kg	52	52	151	151
	6.6	Energy consumption according to VDI cycle	kWh/h	0.73	0.73	0.91	0.91
Misc.	8.1	Type of drive control		AC speedCONTROL			
	8.4	Sound pressure level at operator's ear as per EN 12053	dB (A)	66			

¹⁾ Specification battery voltage/nominal capacity at K20; at K5: 24V, 88Ah

In accordance with VDI Guideline 2198 this specification sheet provides details of the standard truck only. Non-standard tyres, different masts, optional equipment, etc. may result in different values.

Benefit from the advantages



Centralized control instruments



High level of safety due to low ground clearance



Ergonomic tiller head



Optimized visibility through mast

Innovative drive and control technology

Motors with 3-phase AC technology offer many advantages and more efficiency while simultaneously reducing the operating costs thanks to the perfect match with our own controllers:

- High efficiency levels with excellent energy management.
- Rapid directional change without delay.
- No carbon brushes - maintenance-free drive motor.

Energy-efficient operation

Economic energy management increases the efficiency and lifetime of the battery and components:

- Intelligent automatic shut-off: After 30 minutes without use, the truck automatically shuts off.
- Energy recovery due to regenerative braking when decelerating.

Optimal visibility

- Optimum visibility of the fork tips at any height thanks to low frame height and optimised visibility through mast.
- Important instruments such as battery discharge indicator, hourmeter, emergency disconnect and key are centrally located on the truck.
- Sufficient storage space
- Clip pad (EJC M13 ZT)

Ergonomic operation

The truck is perfectly adapted to the ergonomic needs of the operator:

- Reduced force required while steering due to low-mounted tiller.
- Dual-sided operation of tiller handle for ergonomic and safe use.

Safe operation

Various safety measures reduce the risk of injury for operators and guarantee a

high level of safety:

- Reduced risk of foot injuries due to low ground clearance of only 30 mm.
- Additional protection due to completely closed frame and optimised visibility on the mast.

Batteries and charging technology

- EJC M10 ZT: Maintenance-free gel battery 24 V / 105 Ah.
- EJC M13 ZT: Integrated 160-Ah battery ensures a long service life.
- Built-in charger for easy charging at any standard mains socket.

Options

The EJC M10/M13 ZT with duplex mast is available in the lift heights 2300 mm, 2500 mm, 2900 mm and 3300 mm.

Jungheinrich UK Ltd.

Head Office:
Sherbourne House
Sherbourne Drive
Tilbrook
Milton Keynes MK7 8HX
Telephone 01908 363100
Fax 01908 363180

info@jungheinrich.co.uk
www.jungheinrich.co.uk

The German production facilities in Norderstedt, Moosburg and Landsberg are certified. **ISO 9001**
ISO 14001

Jungheinrich fork lift trucks meet European safety requirements.



JUNGHEINRICH
Machines. Ideas. Solutions.