

Manoeuvrable and compact

Lateral battery exchange

Optimum driving characteristics with ProTracLink



## EJE 114/116/118/120

Electric pedestrian pallet truck (1,400/1,600/1,800/2,000 kg)

The EJE Series 1 pallet trucks represent a particularly efficient means of loading and unloading HGVs as well as transporting pallets over short distances. Due to its short front end dimension (L2) of just 486 mm (short version), the EJE can be manoeuvred in very restricted spaces. A number of entry aids guarantee smooth handling of a wide variety of load carriers.

The 3-phase AC drive motor with optimised efficiency ensures high speed and powerful acceleration. This facilitates fast and efficient throughput of goods.

Batteries up to 375 Ah in combination with excellent energy management ensure long operating times. Operations beyond one shift enabled by the quick, lateral battery exchange (optional from EJE 116).

Safe operation facilitated by the low-mounted, long tiller. It

maintains the necessary distance between the operator and the truck. This is particularly beneficial when cornering.

The optional foot protection tiller ensures safe operation in confined spaces. The crawl speed button also facilitates safe travel with the tiller in the upright position. At the touch of a button, the brake is released and activation of the travel switch automatically reduces the speed of travel significantly.

The optional silentDRIVE noise-reducing version allows for operation in noise-sensitive environments.

Its multifunctional tiller arm is full of innovations: Sealed sensor system (IP 65) for maximum breakdown protection, rocker switches with contactless electronics for precise operation in any tiller position, ergonomically arranged switches.

 **JUNGHEINRICH**

# EJE 114/116/118/120

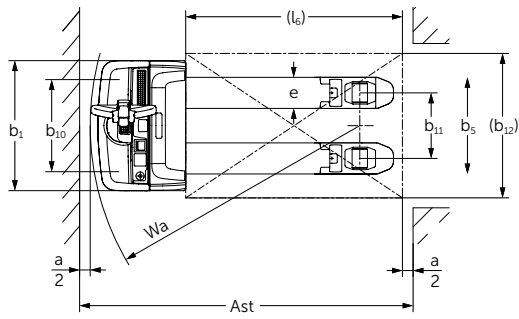
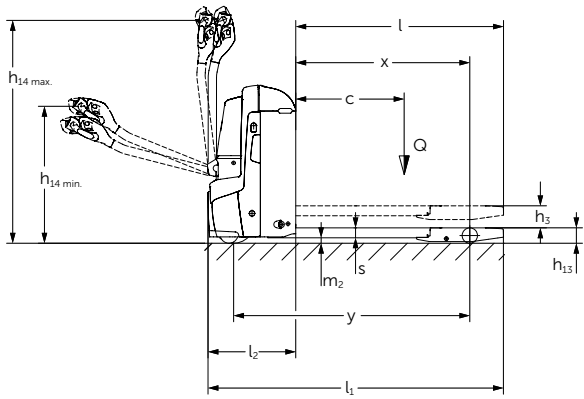

# Technical data in line with VDI 2198

		Jungheinrich					
			EJE 114	EJE 116	EJE 118	EJE 120	
Identification	1.1	Manufacturer (abbreviation)					
	1.2	Model					
	1.3	Drive	Electric				
	1.4	Manual, pedestrian, stand-on, seated, order picker operation	pedestrian				
	1.5	Load capacity/rated load	Q t	1.4	1.6	1.8	2
	1.6	Load centre distance	c mm	600			
	1.8	Load distance	x mm	908 <sup>2)</sup>			
	1.9	Wheelbase	y mm	1,252 <sup>2)4)</sup>			
	Weights	2.1.1	Net weight incl. battery (see row 6.5)	kg	405	420	420
2.2		Axle loading, laden front/rear	kg	655 / 1,150	695 / 1,325	760 / 1,460	785 / 1,635
2.3		Axle loading, unladen front/rear	kg	322 / 83	331 / 89	331 / 89	331 / 89
Wheels / frame	3.1	Tyres	PU/PU				
	3.2	Tyre size, front	mm	Ø 230 x 70			
	3.3	Tyre size, rear	mm	Ø 80 x 90 / 80 x 70 / 80 x 35	Ø 85 x 110 / 85 x 85 / 85 x 44	Ø 85 x 110 / 85 x 85 / 85 x 44	Ø 85 x 110 / 85 x 85 / 85 x 44
	3.4	Additional wheels (dimensions)	mm	Ø 100 x 40			
	3.5	Wheels, number front/rear (x = driven wheels)		1x +2/2 4			
	3.6	Tread width, front	b <sub>10</sub> mm	500	510	510	510
	3.7	Tread width, rear	b <sub>11</sub> mm	363			
Basic dimensions	4.4	Lift	h <sub>3</sub> mm	122			
	4.9	Height of tiller in drive position min. / max.	h <sub>14</sub> mm	750 / 1,237			
	4.15	Height, lowered	h <sub>13</sub> mm	85			
	4.19	Overall length	l <sub>1</sub> mm	1,636 <sup>4)</sup>			
	4.19.1	total length (long)	mm	1,777 <sup>4)</sup>			
	4.20	Length to face of forks	l <sub>2</sub> mm	486 / 627 <sup>4)</sup>			
	4.21	Overall width	b <sub>1</sub> /b <sub>2</sub> mm	720			
	4.22	Fork dimensions	s/e/l mm	55 / 150 / 1,150	55 / 172 / 1,150	55 / 172 / 1,150	55 / 172 / 1,150
	4.25	Width across forks	b <sub>5</sub> mm	513	535	535	535
	4.32	Ground clearance, centre of wheelbase	m <sub>2</sub> mm	35			
	4.33	Aisle width for pallets 1000 x 1200 crossways	Ast mm	2,248 <sup>3)4)</sup>			
4.33.4	Aisle width for pallets 800 x 1200 crossways	Ast mm	2,251 <sup>3)4)</sup>				
4.35	Turning radius	W <sub>a</sub> mm	1,441 <sup>2)4)</sup>				
Performance data	5.1	Travel speed, laden/unladen	km/h	5 / 5	6 / 6	6 / 6	6 / 6
	5.2	Lift speed, laden/unladen	m/s	0.04 / 0.04			
	5.3	Lowering speed, laden/unladen	m/s	0.05 / 0.04			
	5.8	Max. gradeability, laden/unladen	%	8 / 20	10 / 20	9 / 20	8 / 20
	5.10	Service brake		regenerative			
Electrics	6.1	Drive motor, output S2 60 min.	kW	0.9	1.1	1.1	1.1
	6.2	Lift motor, output at S3 15%	kW	0.8	1.2	1.2	1.2
	6.3	Battery as per DIN 43531/35/36 A, B, C, no		B			
	6.4	Battery voltage/nominal capacity K5	V/Ah	24 / 150			
	6.5	Battery weight	kg	151			
	6.6	Energy consumption as per EN 16796	kWh/h	0.31	0.31	0.3	0.34
		CO- Equivalent as per EN 16796	kg/h	0.2			
	6.7	Throughput	t/h	79	93	104	117
6.8	Energy consumption at max. throughput	kWh/h	0.56	0.66	0.62	0.7	
Misc.	8.4	Sound pressure level at operator's ear as per EN 12053	dB (A)	61			

<sup>1)</sup> Load section lowered: + 50 mm

<sup>2)</sup> Load section lowered: + 56 mm

<sup>3)</sup> Load section lowered: + 68 mm

<sup>4)</sup> with lateral battery exchange: M - M SBE + 72 mm; L - L SBE + 53 mm

# Benefit from the advantages



Increased visibility with reflectors



Built-in charger (optional)



Ergonomic tiller arm

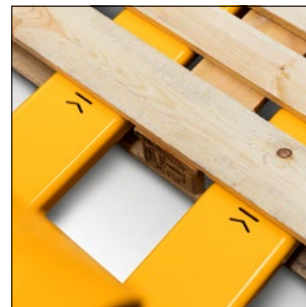

Entry aids and marking on forks

## Innovative 3-phase AC technology

Jungheinrich 3-phase AC motors provide greater performance while simultaneously reducing operating costs:

- High efficiency levels with excellent energy management.
- Powerful acceleration.
- Rapid directional change without delay.
- Two-year warranty on the drive motor.

## Long operating times available with lead-acid battery

- The energy-saving 3-phase AC technology, combined with battery capacities of up to 375 Ah, enables long operating times.
- Multi-shift operation with the optional lateral battery exchange.
- Built-in charger (optional) for straightforward charging at any mains socket – also available with quick charge function for charging during a shift.

## Fully informed at all times

Optional 2-inch display as a central display and setting instrument:

- Battery discharge status, number of operating hours, error codes and a selection of 3 travel programs.
- Activation of the truck by EasyAccess via softkey, PIN code or transponder card (optional).

## Optimum cornering

Sprung and cushioned support wheels linked via the ProTracLink torsion bar distribute stabilising forces dependent on

travel conditions:

- i.e. evenly over all wheels during straight-line travel,
- concentrated on the outer castor wheel when cornering.

## Work ergonomically

The tiller head is perfectly adapted to the ergonomic needs of the operator:

- A clear colour coding system and buttons with abrasion resistant symbols for intuitive operation.
- Optimally adaptable grip position.
- Crawl speed button on the underside of the tiller arm for quick access and easy operation with the tiller in the vertical position.
- Non-contact sensor system with IP 65 protection, hence lowest risk of breakdown.
- Rocker switch for consistently good operation in all tiller positions.

## Optimised pallet entry

- Forks with fork tips tilted by 3° ensure smooth entry into closed pallets.
- A large number of entry and exit aids makes pallet handling even easier. Moreover, all forks have a mark for receiving transverse pallets. This minimises pallet damage.

## Lower maintenance costs

3-phase AC technology ensures significant and long-term reduction in operating costs:

- Maintenance-free 3-phase AC drive motor with no carbon brushes.
- Easy access to all components through one-piece front cover secured by only 2 screws.
- Excellent protection against dust and humidity through enclosure of controller and plugs in accordance with IP 54.
- ProTracLink: Level equalisation ensures reduced castor wheel wear when approaching ramps at an angle.
- Wide-tread version (optional): Wide drive wheel and wide support wheels of the torsion bar ensure a safe ride, even on longitudinal joints (e.g. cold store trailers).

## Additional equipment

- Buzzer instead of horn.
- Load guard.
- Wide-tread wheels and rollers.
- Cold store version.
- silentDRIVE.

## Lithium-ion technology

- High degree of availability thanks to extremely short charging times.
- No battery exchange required.
- Cost savings due to longer service life and low maintenance compared with lead-acid batteries.
- No charging rooms and ventilation required as there is no build up of gas.
- Longer service life with 5-year Jungheinrich guarantee.

## Jungheinrich UK Ltd.

Head Office:  
Sherbourne House  
Sherbourne Drive  
Tilbrook  
Milton Keynes MK7 8HX  
Telephone 01908 363100  
Fax 01908 363180

info@jungheinrich.co.uk  
www.jungheinrich.co.uk

The German production facilities in Norderstedt, Moosburg and Landsberg are certified.

ISO 9001  
ISO 14001

Jungheinrich fork lift trucks meet European safety requirements.



**JUNGHEINRICH**